

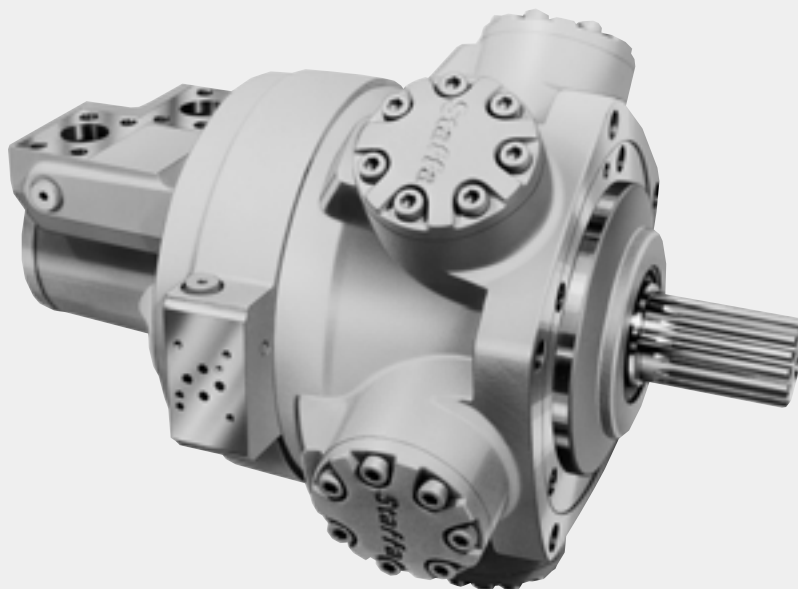

Kawasaki Motors Corp., U.S.A.
Precision Machinery Division

HMC 045

**Staffa Fixed Displacement
Hydraulic Motor**



CONTENTS

	Page
1. General Description	2
2. Functional Symbols	2
3. Model Code	3
4. Performance Data:	
Motor selection	4
Rating definitions	4
Output torques	5
Bearing life	6
Volumetric efficiency	6
5. Circuit and Application Notes:	
Displacement selection	7
Starting torques	7
Low speed operation	7
Small displacements	7
High back pressure	7
Boost pressure	7
Cooling flow	8
Motor casing pressure	8
6. Hydraulic Fluids	8
7. Temperature Limits	8
8. Filtration	8
9. Noise Levels	8
10. Polar Moment of Inertia	8
11. Mass	8
12. Installation Data:	
General	8
Crankcase drain	8
Start-up	9
13. Installation Dimensions	9 to 11

1. GENERAL DESCRIPTION

Kawasaki "Staffa" high torque, low speed radial piston motors use hydrostatic balancing techniques to achieve high efficiency, combined with good breakout torque and smooth running capability.

The HMC series dual displacement models have two pre-set displacements which can be chosen from a wide range to suit specific application requirements. The displacements are hydraulically selected by a directional control valve which can be remote from, or mounted directly on, the motor. Displacements can be changed when the motor is running.

The range of HMC motors extends from the HMC010 of 202 cm³ (12.3 in³) to the HMC325 of 5330 cm³ (325 in³) displacement.

These motors are also available in a continuously variable version using either hydro-mechanical or electro-hydraulic control methods.

Other mounting options are available on request to match many of the competitor interfaces.

The HMC045 is one of 8 frame sizes and is capable of developing torques up to 2930 Nm (2160 lbf ft) with a continuous output power up to 80 kW (108 hp).

The Kawasaki "Staffa" range also includes fixed displacement motors, plus matching brakes and gearboxes to extend the torque range.

2. FUNCTIONAL SYMBOLS

All model types with variants in model code positions **6** & **7**.

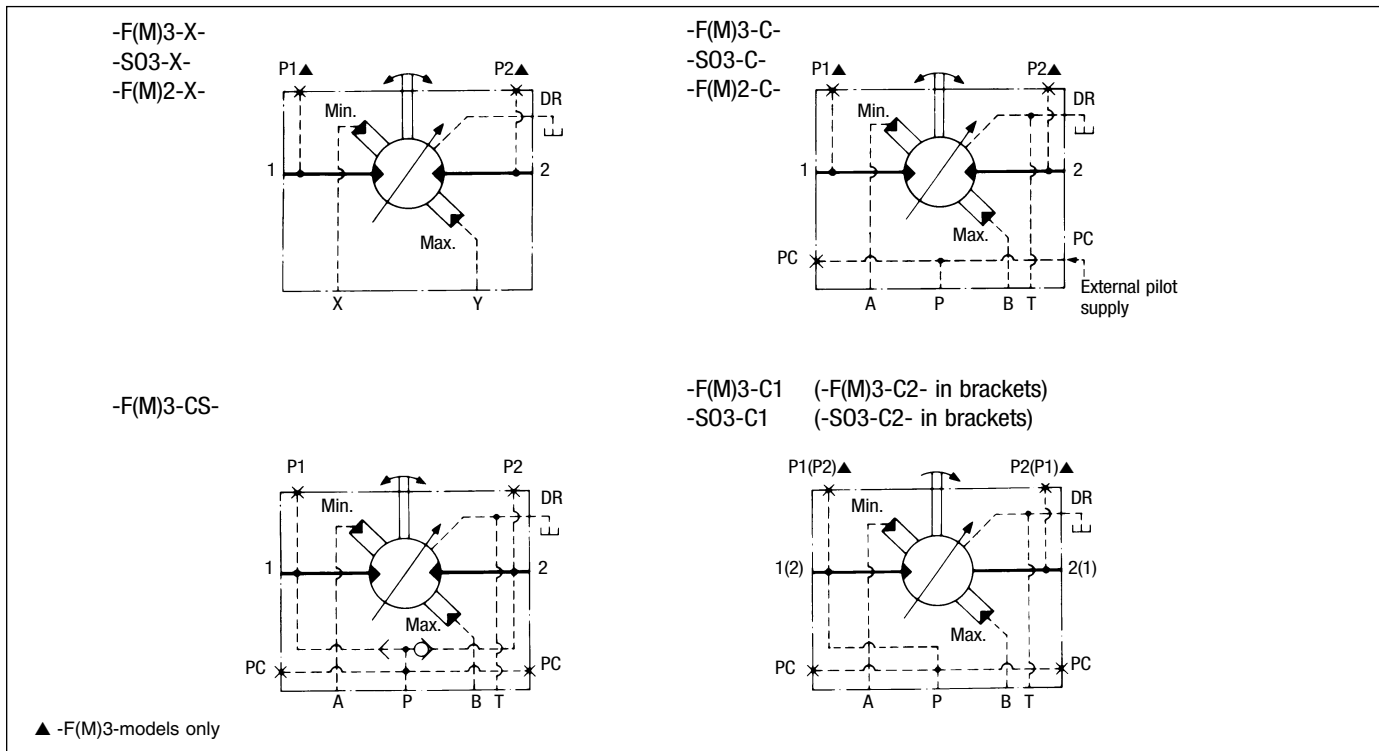

3. MODEL CODE

Features shown in brackets () may be left blank according to requirements.
All other features must be specified.

(F)-HM(*)C045-**-**-**-**-**-**-*(T*)-30-(PL**)**

1

2

3

4

5

6

7

8

9

10

1 FLUID TYPE

Blank = Petroleum oil
F3 = Phosphate ester (HFD fluid)
F11 = Water-based fluids (HFA,
HFB and HFC)

2 MODEL TYPE

Blank = Standard ("HMC")
M = To NCB (UK) specification
463/1981 ("HMMC")

3 SHAFT TYPE

P* = Cylindrical shaft with
parallel key
S* = Cylindrical, 17 splines to
BS 3550
Q* = Female, 21 splines to BS
3550
Z* = Cylindrical shaft to DIN
5480 (W55 x 3 x 7h)

* For installations where shaft is vertically
upwards specify "V" after shaft type letter to
ensure that additional high level drain port is
provided.

4 HIGH DISPLACEMENT CODE

35 to 45 in³, in 5 in³ steps

5 LOW DISPLACEMENT CODE

05 to 30 in³, in 5 in³ steps

6 MAIN PORT CONNECTIONS

Models with 3" distributor valve
S03 = 6-bolt (UNF) flange (Staffa
original valve housing)
F3 = SAE 1¹/₄" 4-bolt (UNC)
flanges
FM3 = SAE 1¹/₄" 4-bolt (metric)
flanges

Models with 2¹/₄" distributor valve▼
F2 = SAE 1" 4-bolt (UNC)
flanges
FM2 = SAE 1" 4-bolt (metric)
flange

▼ 2¹/₄" valve reduces overall length but may
affect maximum permissible speed and power
- consult Kawasaki.

7 DISPLACEMENT CONTROL PORTS (AND SHUTTLE VALVE)

Threaded ports/bi-directional shaft
rotation:

X = X and Y ports G¹/₄" (BSPF
to ISO 228/1)

ISO 4401 size 03 mounting face/bi-
directional shaft rotation:

C = No shuttle valve
CS■ = With shuttle valve

ISO 4401 size 03 mounting
face/uni-directional shaft rotation
(viewed on shaft end):

C1 = Control pressure from main
port 1 (shaft rotation
clockwise with flow into
port 1)

C2 = Control pressure from main
port 2 (shaft rotation
counter-clockwise with
flow into port 2)

■ Only available with "F(M)3" type main port
connections **6**

8 TACHO/ENCODER DRIVE

T = Staffa original tacho drive
T1 = Suitable for Hohner 3000
series encoders. (Encoder
to be ordered separately)

Omit if not required.

9 DESIGN NUMBER, 30 SERIES

Subject to change. Installation and
performance details remain
unaltered for design numbers 30 to
39 inclusive.

10 SPECIAL FEATURES

PL** = Non-catalogued features,
e.g.:
High pressure shaft seals
Alternative port connections
Stainless steel shaft sleeves
Alternative encoder and tacho drives
Motor valve housing orientation
Shaft variants
Special paint

** Number assigned as required to specific
customer build.

4. PERFORMANCE DATA

Performance data is valid for Staffa HMC045 motors fully run in and operating with petroleum oil. Leakage values are at fluid viscosity of 50 cSt (232 SUS).

MOTOR SELECTION

Use table 1 to select appropriate displacements for each application. Refer to table 2 for pressure and speed limits when using fire-resistant fluids.

TABLE 1

Displacement code* (Model code positions 4 & 5)		45	40	35	30	25	20	15	10	05
Displacement	cm ³	737	655	573	491	410	327	246	163	81
	in ³	45	40	35	30	25	20	15	10	5
Average actual running torque	Nm/bar	10.65	9.4	8.04	6.88	5.68	4.4	3.2	1.55	0
	lbf ft/psi	0.542	0.478	0.409	0.35	0.289	0.224	0.163	0.077	0
Max. continuous speed	r/min	450	550	600	600	600	600	600	600	1000
Max. continuous output power	kW	80	72	64	54	44	34	24	12	0
	hp	108	97	85	72	59	46	33	16	0
Max. intermittent output power	kW	96	85	78	66	55	42	31	15	0
	hp	126	114	104	88	74	57	41	20	0
Max. continuous pressure	bar	250	250	250	250	250	250	250	250	17 ♦
	psi	3626	3626	3626	3626	3626	3626	3626	3626	250 ♦
Max. intermittent pressure	bar	275	275	275	275	275	275	275	275	17 ♦
	psi	4000	4000	4000	4000	4000	4000	4000	4000	250 ♦

* Intermediate displacements are available to special order.

♦ See "Small displacements" page 7 for information about higher pressure applications.

TABLE 2

Fluid type	Pressure, bar (psi)		Max. speed r/min
	Continuous	Intermittent	
HFA, 5/95% oil-in-water emulsion	103 (1500)	138 (2000)	50% of limits for petroleum oil
HFB, 60/40% water-in-oil emulsion	138 (2000)	172 (2500)	As for petroleum oil
HFC, water glycol	103 (1500)	138 (2000)	50% of limits for petroleum oil
HFD, phosphate ester	250 (3625))	275 (4000)	As for petroleum oil

RATING DEFINITIONS

● CONTINUOUS RATING

For continuous duty the motor must be operating within each of the maximum values for speed, pressure and power as specified for each displacement code.

● INTERMITTENT RATING

Operation within the intermittent power rating (up to the maximum continuous speed) is permitted on a 15% duty basis, for periods up to 5 minutes maximum.

● INTERMITTENT MAX. PRESSURE

Up to 275 bar (4000 psi) is allowable on the following basis:

- Up to 50 r/min: 15% duty for periods up to 5 minutes maximum.
- Over 50 r/min: 2% duty for periods up to 30 seconds maximum.

OUTPUT TORQUES

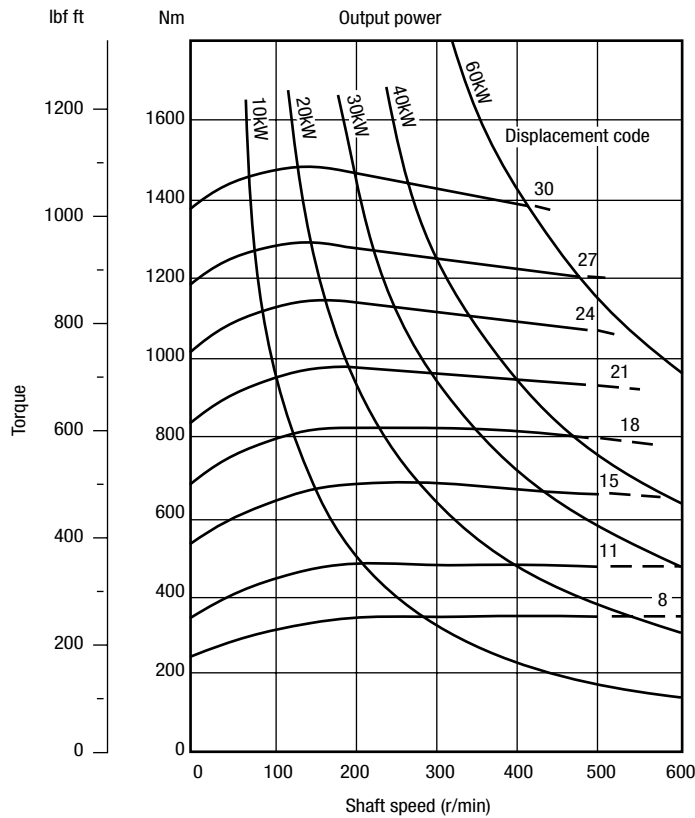

The torque curves indicate, for each displacement, the maximum output torque of the motor with an inlet pressure of 250 bar (3626 psi) and zero output pressure. High return line pressures will reduce the torque for any given pressure differential.

The solid line portion of each curve indicates the levels of maximum torque and speed that are permitted on a "continuous" basis.

The dotted portion of each curve indicates the levels of torque and speed at which the motor can operate at an "intermittent" rating.

The starting torques shown on the graph are average and will vary with crankshaft angle.

BEARING LIFE

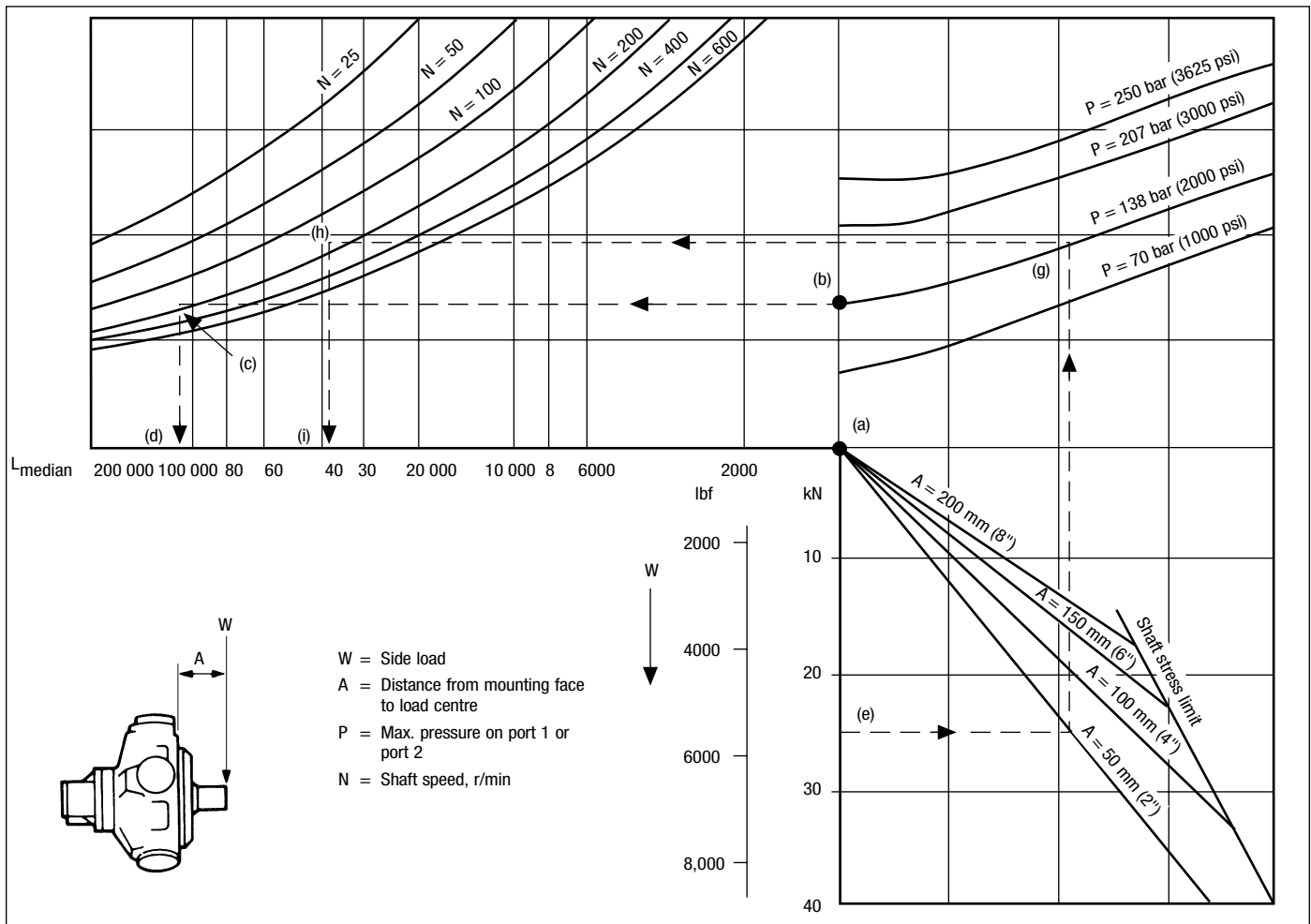

The nomograph allows the median bearing life to be determined for conditions of:

1. No side load and no axial thrust
2. Side load and no axial thrust

▲ To determine L10 life predictions per ISO 281-1-1977 multiply the mean figure by 0.2.

For more precise life prediction, or where axial thrusts are incurred, a computer analysis can be provided by Kawasaki on receipt of machine duty cycle.

● **SHAFT STRESS LIMIT**

The shaft stress limit in the nomograph is based on the fatigue rating of the shaft. Infrequent loading above these limits may be permitted; consult Kawasaki.

VOLUMETRIC EFFICIENCY

The nomograph on page 7 enables the average volumetric efficiency, crankcase (drain) leakage and "winch slip"/shaft creep speed to be estimated.

Example (follow chain dotted line):

Given:

1. Pressure175 bar (2500 psi)
2. Displacement code40 (in³/r)
3. Speed200 r/min

To obtain:

4. Volumetric efficiency93.5%
5. Crankcase leakage3.5 l/min
(215 in³/min)
6. Shaft creep speed8.5 r/min

The shaft creep speed occurs when the load attempts to rotate the motor against closed ports as may occur, for example, in winch applications.

HMC045

Example 1 (follow chain dotted line):

Side load (W)	a) 0
System pressure (P)	b) 138 bar (2000 psi)
Speed (N)	c) 200 r/min
Median bearing life	d) 112 000 hrs
L10 bearing rating = median x 0.2	22 400 hrs

Example 2 (follow chain dotted line):

Side load (W)	e) 25 kN (5600 lbf)
Load offset (A) from motor mounting face	f) 50 mm (2.0 in)
System pressure (P)	g) 138 bar (2000 psi)
Speed (N)	h) 200 r/min
Median bearing life	i) 37 500 hrs
L10 bearing rating = median x 0.2	7500 hrs

VOLUMETRIC EFFICIENCY

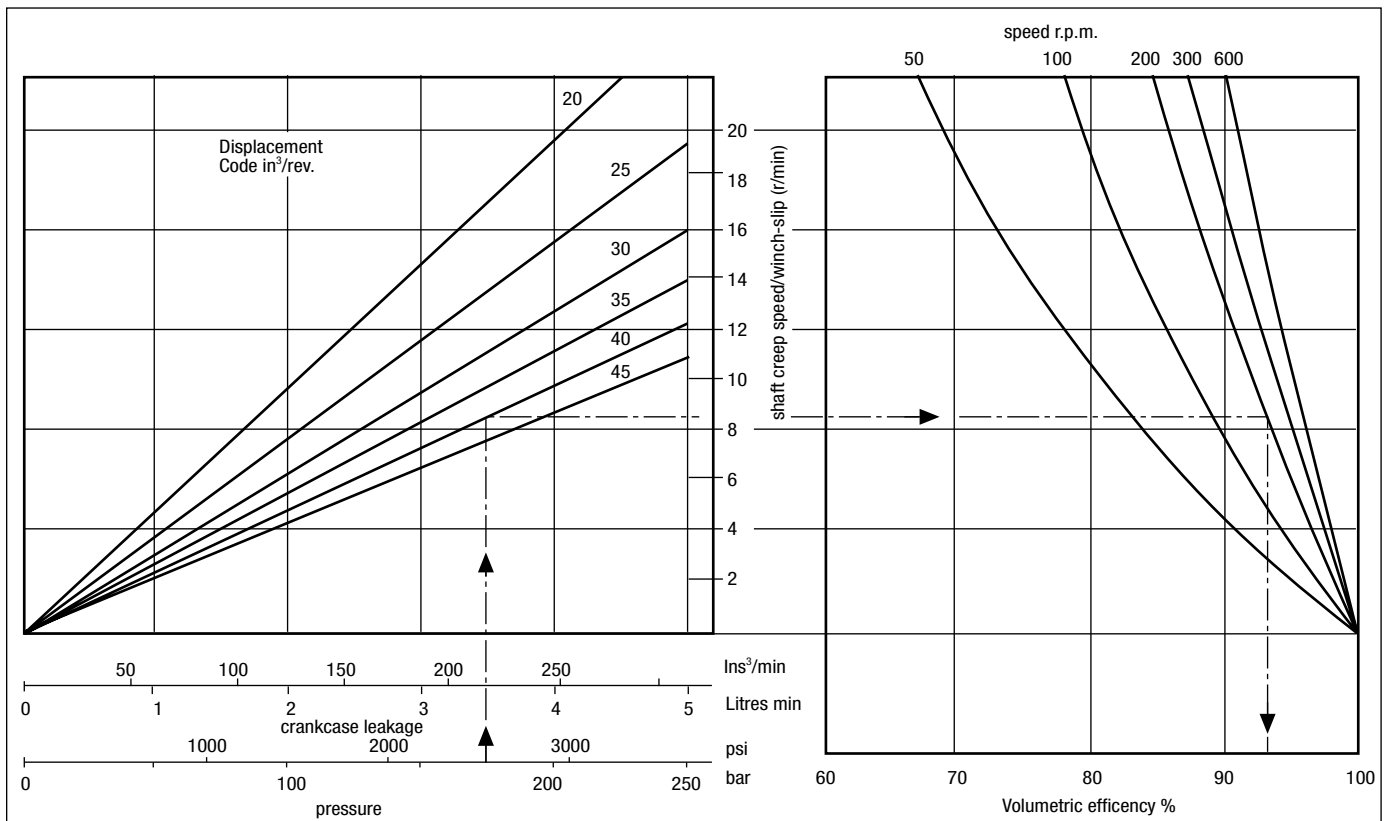

5. CIRCUIT AND APPLICATION NOTES

DISPLACEMENT SELECTION

To select either displacement, a pressure at least equal to 2/3 of the motor inlet/outlet pressure (whichever is higher) is required. In most applications the motor inlet pressure will be used.

For inlet/outlet pressures below 3,5 bar (50 psi) a minimum control pressure of 3,5 bar (50 psi) is required. In the event of loss of control pressure the motor will shift to its highest displacement.

For rapid reversing applications it is recommended to externally source the control oil supply direct from the system pump (use displacement control type "X" or "C" - *not* "CS", "C1" or "C2" - in model code position **7**).

STARTING TORQUES

The starting torques shown on the graph on page 4 are average and will vary with system parameters. For motors with low displacement below 15 in³ and starting under load it is recommended to select high displacement for start-up.

LOW SPEED OPERATION

(High displacement mode)
Minimum operating speeds are determined by load conditions (load inertia, drive elasticity, etc.) For operation at speeds below 6 r/min consult Kawasaki.

SMALL DISPLACEMENTS

(5 in³ and below)

The pressures given in the table on page 4 for displacement code "05" (and below) are based on 1000 r/min output shaft speed. These pressures can be increased for shaft speeds less than 1000 r/min; consult Kawasaki for details.

In addition to 5 in³, a zero swept volume displacement (for free wheeling requirements) is available on request, subject to Kawasaki approving the application.

HIGH BACK PRESSURE

When both inlet and outlet ports are pressurized continuously, the lower pressure in one port must not exceed 70 bar (1000 psi) at any time. Consult Kawasaki on applications beyond this limit. Note that high back pressures reduce the effective torque output of the motor.

BOOST PRESSURE

When operating as a motor the outlet pressure should equal or exceed the crankcase pressure. If pumping occurs (i.e. overrunning loads) then a positive pressure, "P", is required at the motor ports. Calculate "P" (bar/psi) from the appropriate formula:

$$P \text{ (bar)} = 1 + \frac{N^2 \times V^2}{D_{\text{bar}}} + C$$

Where:

- C = crankcase pressure, bar
- D = see table
- N = speed, r/min
- V = displacement, cm³/r

$$P \text{ (bar)} = 14.5 + \frac{N^2 \times V^2}{D_{\text{psi}}} + C$$

Where:

- C = crankcase pressure, psi
- D = see table
- N = speed, r/min
- V = displacement, cm³/r

Port connection type	D value
F3, FM3, SO3	D _{bar} = 1,6 x 10 ¹⁰ D _{psi} = 4.1 x 10 ⁶
F2, FM2	D _{bar} = 3,7 x 10 ⁹ D _{psi} = 9.5 x 10 ⁵

The flow rate of oil needed for the make-up system can be estimated from the crankcase leakage figure (see Volumetric Efficiency graph above) plus an allowance for changing displacement; e.g. to change high to low in 0.25 sec requires 15 l/min (4.0 USgpm).

Allowance should be made for other system losses and also for "fair wear and tear" during the life of the motor, pump and other system components.

COOLING FLOW

Operation within the continuous ratings does not require any additional cooling.

For operating conditions above “continuous”, up to the “intermittent” ratings, additional cooling oil may be required. This can be introduced through the spare crankcase drain holes, or in special cases through the valve spool end cap. Consult Kawasaki about such applications.

MOTOR CASING PRESSURE

With the standard shaft seal fitted, the motor casing pressure should not exceed 3,5 bar (50 psi). On installations with long drain lines a relief valve is recommended to prevent over-pressurizing the seal.

Notes:

1. The casing pressure at all times must not exceed either the motor inlet or outlet pressure.
2. High pressure shaft seals are available to special order for casing pressures of:
Continuous: 10 bar (150 psi)
Intermittent: 15 bar (225 psi)
3. Check installation dimensions (page 9) for maximum crankcase drain fitting depth.

6. HYDRAULIC FLUIDS

Dependent on motor (see Model Code position **1**) suitable fluids include:

- Antiwear hydraulic oils.
- Phosphate esters (HFD fluids)
- Water glycols (HFC fluids)■
- 60/40% water-in-oil emulsions (HFB fluids)■
- 5/95% oil-in-water emulsions (HFA fluids)■

■ Reduced pressure and speed limits, see page 4.

Viscosity limits when using any fluid except oil-in-water (5/95) emulsions are:

Max. off load	2000 cSt (9270 SUS)
Max. on load	150 cSt (695 SUS)
Optimum	50 cSt (232 SUS)
Minimum	25 cSt (119 SUS)

PETROLEUM OIL RECOMMENDATIONS

The fluid should be a good hydraulic grade, non-detergent petroleum oil. It should contain anti-oxidant, anti-foam and demulsifying additives. It must contain antiwear or EP additives. Automatic transmission fluids and motor oils are not recommended.

7. TEMPERATURE LIMITS

Ambient min.	-30°C (-22°F)
Ambient max.	+70°C (158°F)

Max. operating temperature range

	Petroleum oil	Water-containing
Min.	-20°C (-4°F)	+10°C (50°F)
Max.*	+80°C (175°F)	+54°C (130°F)

* To obtain optimum service life from both fluid and hydraulic system components 65°C (150°F) normally is the maximum temperature except for water-containing fluids.

8. FILTRATION

Full flow filtration (open circuit) or full boost flow filtration (closed circuit) to ensure system cleanliness of ISO 4406/1986 code 18/14 or cleaner.

9. NOISE LEVELS

The airborne noise level is less than 66.7 dB(A) DIN (70 dB(A) NFPA) throughout the “continuous” operating envelope.

Where noise is a critical factor, installation resonances can be reduced by isolating the motor by elastomeric means from the structure and the return line installation. Potential return line resonances originating from liquid borne noise can be further attenuated by providing a return line back pressure of 2 to 5 bar (30 to 70 psi).

10. POLAR MOMENT OF INERTIA

Typical data

Displacement code	kg m ²	lb in ²
45	0.044	150
30	0.041	140

11. MASS

Approx. all models: 150 kg (330 lb)

12. INSTALLATION DATA

GENERAL

● Spigot

The motor should be located by the mounting spigot on a flat, robust surface using correctly sized bolts. The diametral clearance between the motor spigot and the mounting must not exceed 0,15 mm (0.006"). If the application incurs shock loading, frequent reversing or high speed running, then high tensile bolts should be used, including one fitted bolt.

● Bolt torque

The recommended torque wrench settings for the mounting bolts are:
M18312±14 Nm (230±10 lbf ft)
5/8 UNF265±14 Nm (195±10 lbf ft)

● Shaft coupling

Where the motor is solidly coupled to a shaft having independent bearings the shafts must be aligned to within 0,13 mm (0.005") TIR.

CRANKCASE DRAIN

The recommended minimum pipe size for drain line lengths up to approx. 5m (15 ft) is 12.0 mm 1/2" bore. For longer drains, increase pipe bore to keep motor casing pressure within specified limits.

Connect to a drain port above motor centre line.

Axis vertical, shaft up

Standard drain port 3/4" - 16 UNF

Additional drain port G1/4" (BSPF)

0,35 bar (5 psi)

Specify “V” at model code position (3) for extra drain port, G1/4" (BSPF). Connect this port into main drain line downstream of a 0,35 bar (5 psi) check valve to ensure good bearing lubrication. Piping arrangement must not allow syphoning from the motorcase. Where this arrangement is not practical, please consult Kawasaki.

Axis vertical, shaft down

Piping (from any drain port) must be taken above level of motorcase to ensure good bearing lubrication. The arrangement must not allow syphoning from the motorcase.

START-UP

Fill the crankcase with system fluid.
Where practical, a short period (30 minutes) of "running in" should be carried out with the motor set to its high displacement (pressure to port Y, or to port B of the size O3 pilot valve).

13. INSTALLATION DIMENSIONS IN MM (INCHES)

HMC045 MOTOR WITH TYPE "F3"/"FM3" (1 1/4" SAE) MAIN PORTS CONNECTION

See additional views for:

Displacement control connections, shaft types, alternative main port connections for 3" valve, and all port connections with 2 1/4" valve

3rd angle projection

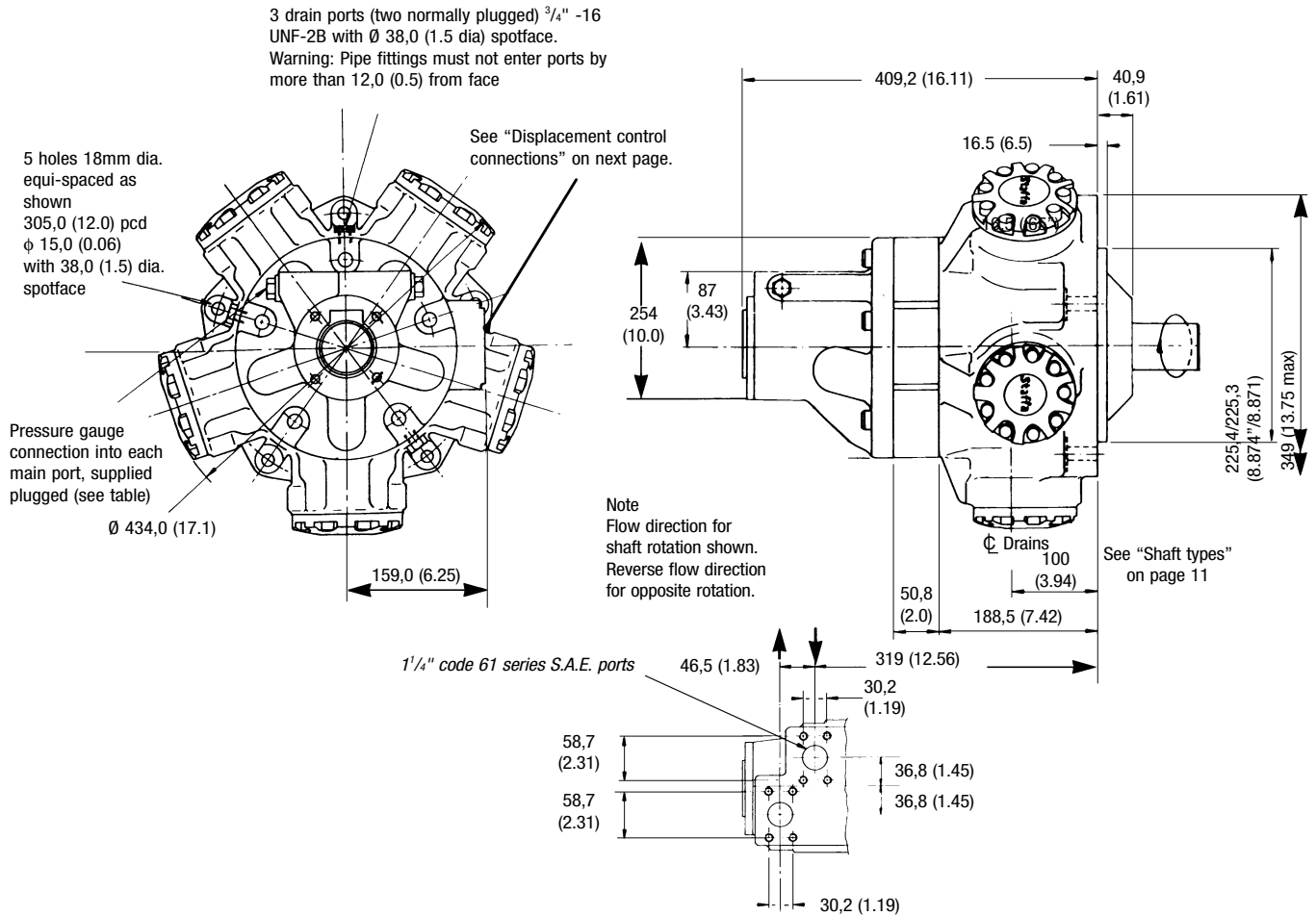
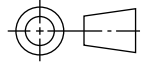

● Suitable for M18 or 5/8" bolts. See "Installation Data".

■ Port connection details

Model code	Flange	Bolt tappings	Pressure gauge connections
F3	1 1/4" SAE code 61 4-bolt flange	7/16"-14 UNC-2B x 27,0 (1.06) deep	9/16"-18 UNF-2B, SAE J475
FM3	1 1/4" SAE code 61 4-bolt flange	M12-6H x P1.75 x 27,0 (1.06) deep	G 1/4" 9BSPF)
S03	Staffa 3" 6-bolt flange, see separate view on next page		
F2	1" SAE code 61 4-bolt flange (Imperial), see separate view on next page		
FM2	1" SAE code 61 4-bolt flange (metric), see separate view on next page		

3" VALVE HOUSING WITH 6-BOLT FLANGE, "S03" IN MODEL CODE POSITION **6**

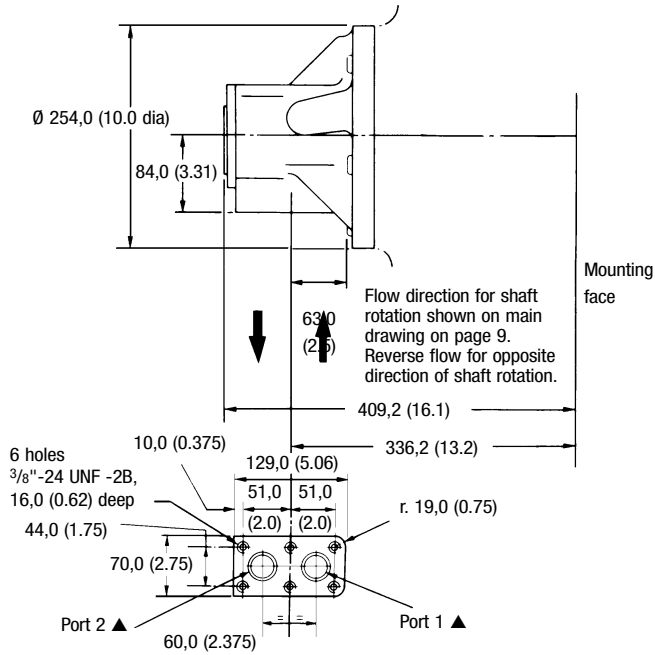

▲ $\varnothing 28$ (1.125 dia), with recess for 31,0 (1.22) i/d x $\varnothing 4$ (0.157 dia) section O-ring

1" SAE 4-BOLT FLANGE, "F2"/"FM2" IN MODEL CODE POSITION **6**

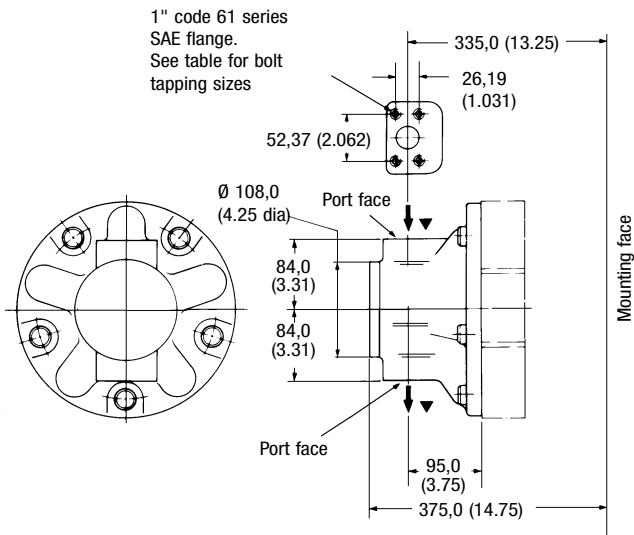

Flange bolt tappings

Model code **6** Bolt tappings

F2 $\frac{3}{8}$ "-16 UNC-2B x 22,0 (0.875) deep
FM2 M10 x p1,5 x 22,0 (0.875) deep

▼ Flow direction for shaft rotation shown on main drawing on page 9. Reverse flow for opposite direction of shaft rotation.

DISPLACEMENT CONTROL CONNECTIONS, MODEL CODE POSITION **7**

Type X
G $\frac{1}{4}$ " (BSPF) tapped ports X and Y

Displacement selection (via remotely located valve \blacklozenge):

High displacement: P to Y; X to T
Low displacement: P to X; Y to T

Types C, CS, C1 and C2
Mounting interface for directional control valve \blacklozenge to: ISO 4401 size O3 ANSI/B93. 7M size D03

Displacement selection:
High displacement: P to B; A to T
Low displacement: P to A; B to T

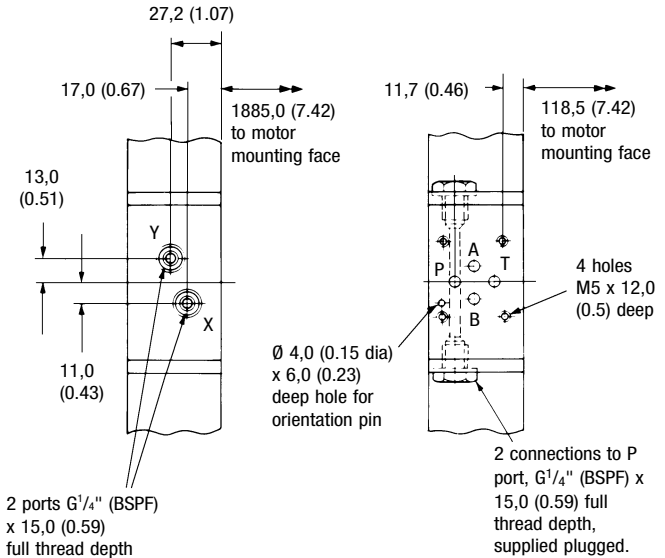

2 ports G $\frac{1}{4}$ " (BSPF) x 15,0 (0.59) full thread depth

2 connections to P port, G $\frac{1}{4}$ " (BSPF) x 15,0 (0.59) full thread depth, supplied plugged.
4 holes M5 x 12,0 (0.5) deep

◆ Displacement selector valve is not supplied with the motor; specify and order separately.

SHAFT TYPE "P", MODEL CODE POSITION 3

Cylindrical shaft with key

Key supplied:

14,046/14,028 (0.5530/0.5523) wide
x 9,037/8,961 (0.3558/0.3528) thick

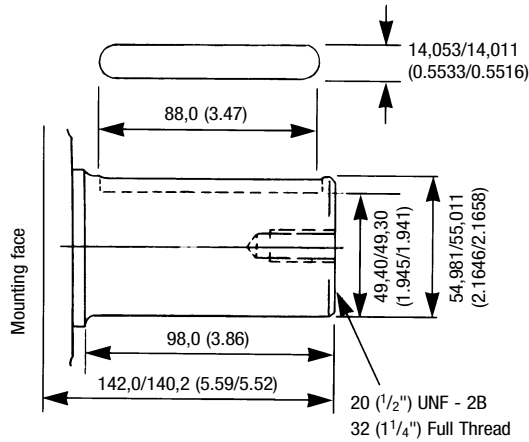

SHAFT TYPE "S", MODEL CODE POSITION 3

Cylindrical shaft with 17 splines to BS 3550-1963

SHAFT TYPE "Z", MODEL CODE POSITION 3

Cylindrical shaft to DIN 5480

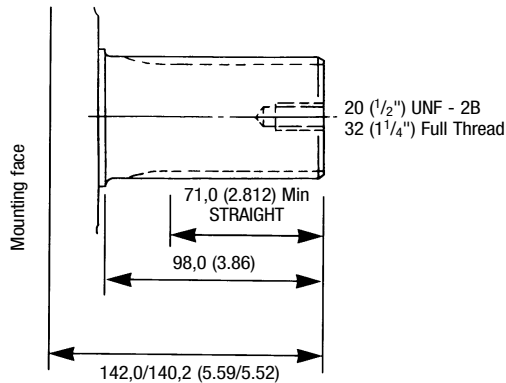

For shaft type "S"

To BS 3550-1963 and ASA.B5. 15-1960

Flat root, side fit, class 1

Pressure angle	30°
Number of teeth	17
Pitch	8/16
Major diameter	56,41/56,29 (2.221/2.216)
Form diameter	50,703/(1.9962)
Minor diameter	50,07/49,60 (1.971/1.953)
Pin diameter	6,096 (0.2400)
Diameter over pins	62,985/62,931 (2.4797/2.4776)

For shaft type "Z"

DIN 5480, W55 x 3 x 17 x 7h

SHAFT TYPE "Q", MODEL CODE POSITION 3

Internally splined to BS 3550; 21 splines

Note: The type "Q" shaft will transmit the maximum torques given on page 3. However, customers should ensure that their own mating shaft will transmit the torque required in their application.

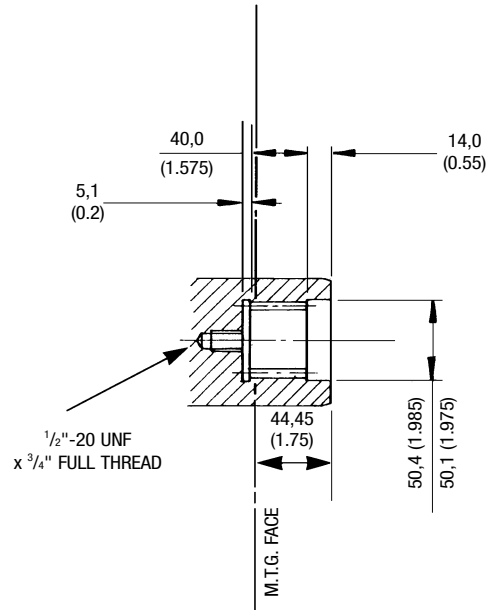

Internal spline to BS 3550-1963

Flat root side fit.

Pressure angle	30°
Number of teeth	21
Pitch	12/24
Major diameter	46,566/46,896 (1.8333/1.8463)
Minor diameter	42,334/42,461 (1.6667/1.6717)
Pin diameter	3,658 (0.1440)
Pin flattened to	3,556 (0.1400)
Diameter between pins	39,169/39,103 (1.5421/1.5395)

Presented by:



Kawasaki Motors Corp., U.S.A.
Precision Machinery Division

5080 36th Street S.E., Grand Rapids, MI 49512 • USA
(616) 949-6500 • Fax (616) 975-3103

www.kawasakipmd.com



**Staffa hydraulic motors are
manufactured to the highest
quality standards in a Kawasaki
ISO 9001 certified facility.
Certification No. 891150**